



VA

三爪中實油壓夾頭（含連接板）

3-jaw wedge type non through-hole power chuck (adapter included)

- 主軸配合件可採用ASA或DIN以搭配機器主軸。

單位：mm

型 式 規 格	拉桿行程 (mm)	爪行程直徑 (mm)	最大容許拉力 (kgf)	最大夾持力 (kgf)	最大使用油壓力 (kgf / cm ²)	最高轉速 (r.p.m.)	重量 (kg)	慣性矩 I (kg · m ²)	適合油壓缸	適合硬爪	適合生爪	外徑夾持範圍 (mm)
V-206A4	20	9.2	1835	5353	26.5	5200	14.5	0.062	MS105C	HJ06	HC06	Ø18-Ø165
V-206A5	20	9.2	1835	5353	26.5	5200	13.9	0.056	MS105C	HJ06	HC06	Ø18-Ø165
V-206A6	20	9.2	1835	5353	26.5	5200	15.8	0.059	MS105C	HJ06	HC06	Ø18-Ø165
V-208A5	21	9.7	2549	7648	25.5	4500	26.8	0.154	MS125C	HJ08	HC08	Ø26-Ø210
V-208A6	21	9.7	2549	7648	25.5	4500	25.6	0.147	MS125C	HJ08	HC08	Ø26-Ø210
V-208A8	21	9.7	2549	7648	25.5	4500	30	0.172	MS125C	HJ08	HC08	Ø26-Ø210
V-210A6	25	8.8	2957	11013	28.6	4000	41.8	0.35	MS125C	HJ10	HC10	Ø26-Ø254
V-210A8	25	8.8	2957	11013	28.6	4000	39.6	0.33	MS125C	HJ10	HC10	Ø26-Ø254
V-210A11	25	8.8	2957	11013	28.6	4000	50	0.417	MS125C	HJ10	HC10	Ø26-Ø254
V-212A6	30	10.5	4181	15907	27.5	3300	67.6	0.76	MS150C	HJ12-1	HC12-1	Ø26-Ø304
V-212A8	30	10.5	4181	15907	27.5	3300	65.5	0.75	MS150C	HJ12-1	HC12-1	Ø26-Ø304
V-212A11	30	10.5	4181	15907	27.5	3300	75.9	0.888	MS150C	HJ12-1	HC12-1	Ø26-Ø304
V-215A8	35	16	8362	25391	32.6	3000	119	2.12	MS200C	HJ15-1	HC15-1	Ø68-Ø381
V-215A11	35	16	8362	25391	32.6	3000	113	2.05	MS200C	HJ15-1	HC15-1	Ø68-Ø381
V-215A15	35	16	8362	25391	32.6	3000	132	2.56	MS200C	HJ15-1	HC15-1	Ø68-Ø381
V-218A8	35	16	8362	25391	32.6	2700	136	3.28	MS200C	HJ15-1	HC15-1	Ø98-Ø450
V-218A11	35	16	8362	25391	32.6	2700	129	3.20	MS200C	HJ15-1	HC15-1	Ø98-Ø450
V-218A15	35	16	8362	25391	32.6	2700	148	3.71	MS200C	HJ15-1	HC15-1	Ø98-Ø450

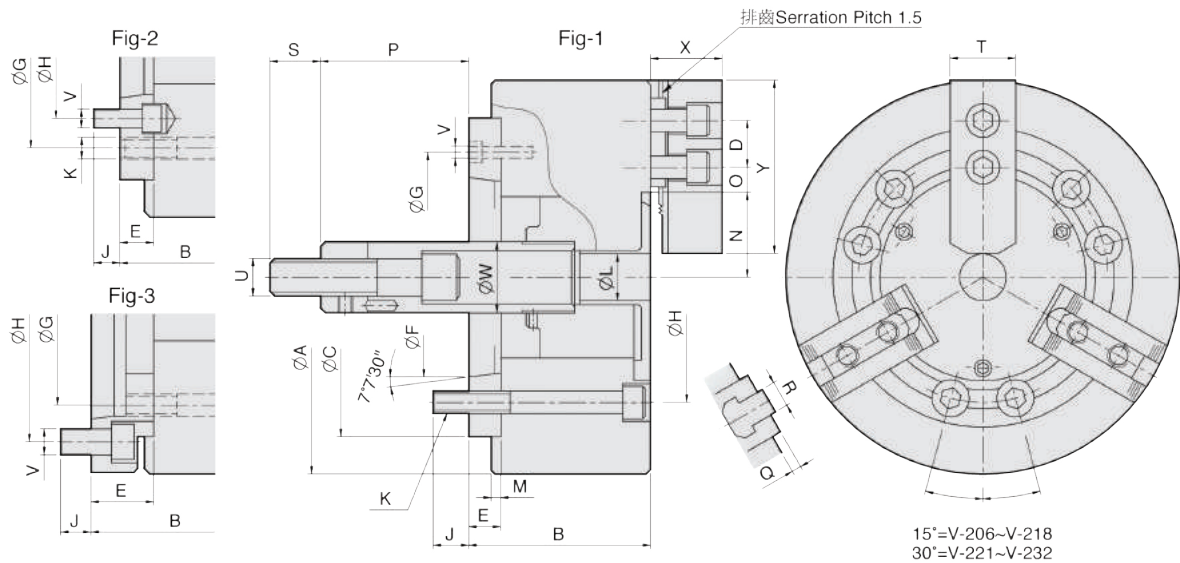

單位：mm

型 式 尺 寸	A	B	C (H6)	D	E	F	G	H	J	K	L	M	N max.	O max.	O min.	P max.	P min.	Q	R	S	T	U	V	W	X	Y	參考圖
V-206A4	165	89	140	20	20	63.513	104.78	82.55	16	6-M10	21	5	38.7	15.25	7.75	84.6	64.6	4	12	36	31	M16x2.0	6-M10	34	39	73	Fig2
V-206A5	165	84	140	20	15	82.563	116	104.78	14	6-M10	21	5	38.7	15.25	7.75	89.6	69.6	4	12	36	31	M16x2.0	3-M6	34	39	73	Fig1
V-206A6	165	104	140	20	35	106.375	104.78	133.35	16	6-M10	21	5	38.7	15.25	7.75	69.6	49.6	4	12	36	31	M16x2.0	6-M12	34	39	73	Fig3
V-208A5	210	103	170	25	23	82.563	133.35	104.78	14	6-M12	25	5	46.75	22.25	8.75	109	88	5	14	36	35	M20x2.5	6-M10	38	41	95	Fig2
V-208A6	210	97	170	25	17	106.375	150	133.35	18	6-M12	25	5	46.75	22.25	8.75	115	94	5	14	36	35	M20x2.5	3-M6	38	41	95	Fig1
V-208A8	210	120	170	25	40	139.719	133.35	171.45	24	6-M12	25	5	46.75	22.25	8.75	92	71	5	14	36	35	M20x2.5	6-M16	38	41	95	Fig3
V-210A6	254	109	220	30	25	106.375	171.45	133.35	18	6-M16	34	5	51.1	30.75	9.75	133	108	5	16	36	40	M20x2.5	6-M12	45	46	110	Fig2
V-210A8	254	102	220	30	18	139.719	190	171.45	25	6-M16	34	5	51.1	30.75	9.75	140	115	5	16	36	40	M20x2.5	3-M8	45	46	110	Fig1
V-210A11	254	134	220	30	50	196.869	171.45	235	28	6-M16	34	5	51.1	30.75	9.75	108	83	5	16	36	40	M20x2.5	6-M20	45	46	110	Fig3
V-212A6	304	125	220	30	25	106.375	171.45	133.35	18	6-M16	34	6	61	48.75	9.75	138	108	5	18	36	50	M20x2.5	6-M12	50	54	130	Fig2
V-212A8	304	118	220	30	18	139.719	190	171.45	25	6-M16	34	6	61	48.75	9.75	145	115	5	18	36	50	M20x2.5	3-M8	50	54	130	Fig1
V-212A11	304	150	220	30	50	196.869	171.45	235	28	6-M16	34	6	61	48.75	9.75	113	83	5	18	36	50	M20x2.5	6-M20	50	54	130	Fig3
V-215A8	381	141	300	43	33	139.719	235	171.45	24	6-M20	—	6	77.5	49.75	21.25	71	36	2	25.5	55	62	M30x3.5	6-M16	60	63	165	Fig2
V-215A11	381	130	300	43	22	196.869	260	235	32	6-M20	—	6	77.5	49.75	21.25	82	47	2	25.5	55	62	M30x3.5	3-M10	60	63	165	Fig1
V-215A15	381	165	300	43	57	285.775	235	330.2	29	6-M20	—	6	77.5	49.75	21.25	47	12	2	25.5	55	62	M30x3.5	6-M24	60	63	165	Fig3
V-218A8	450	141	300	43	33	139.719	235	171.45	24	6-M20	—	6	108	49.75	21.25	59	24	2	25.5	55	62	M30x3.5	6-M16	60	63	165	Fig2
V-218A11	450	130	300	43	22	196.869	260	235	32	6-M20	—	6	108	49.75	21.25	70	35	2	25.5	55	62	M30x3.5	3-M10	60	63	165	Fig1
V-218A15	450	165	300	43	57	285.775	235	330.2	29	6-M20	—	6	108	49.75	21.25	35	0	2	25.5	55	62	M30x3.5	6-M24	60	63	165	Fig3