



CM.B

油壓迴轉缸集水盒

Hydraulic cylinder coolant collector

1. 可安裝行程確認裝置及油水回收。
2. 近接開關須另購。

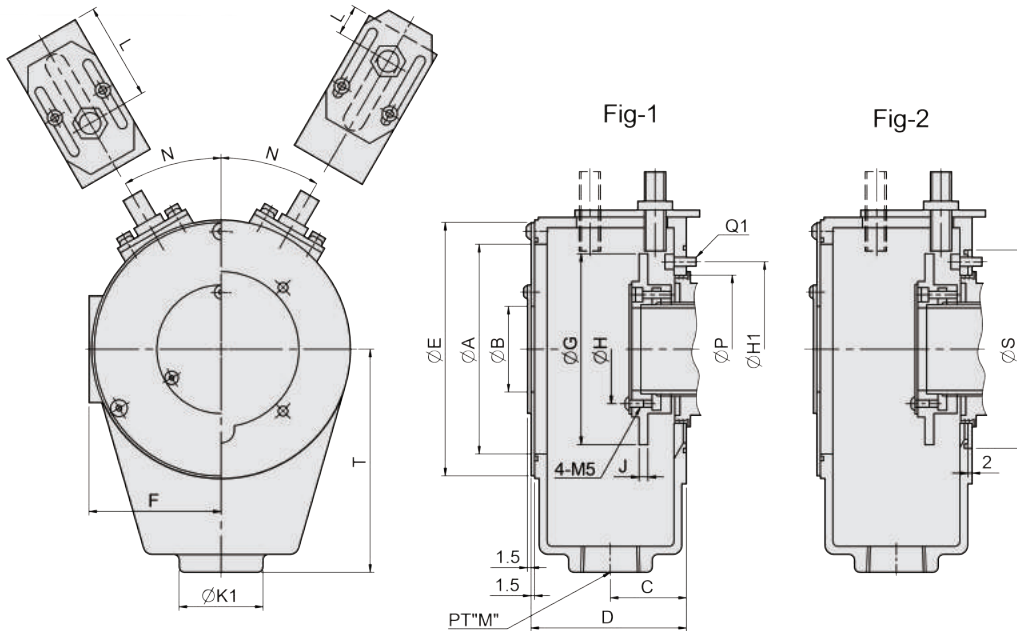

單位：mm

型 式 尺	A	B	C	D	E	F	G	H	J	L max.	L min.	N	P	S	T	M	H1	K1	Q1	參考圖	適合 油壓缸	重量 (kg)
CM09B	82.5	30	35	71.5	106	55.5	77	43	5	47.5	17.5	30	67	90	105	PT 3/4"	76	44	4-M4	Fig2	M0928	0.85
CM10B1	82.5	40	35	71.5	106	55.5	77	52	5	47.5	17.5	30	75	—	105	PT 3/4"	88	44	6-M5	Fig1	M1036	1.0
CM12B	117.5	48	42	85.5	142	74	107	61	5	60.5	17.5	30	87	—	130	PT 1"	98	47	4-M5	Fig1	M1236, M1246, MK1246, MM1246A	1.6
CM15B8	117.5	55	42	85.5	142	74	107	67	5	60.5	17.5	30	98	—	130	PT 1"	110	47	4-M6	Fig1	M1546, M1552, MK1452	1.6
CM18B	155	80	42.5	86.5	184	94	147	92	5	58.5	17.5	30	123	—	150	PT 1"	155	47	4-M6	Fig1	M1868, M1875	2.0
CM18BK	155	80	42.5	86.5	184	94	147	97	5	60.5	19.5	30	126	175	150	PT 1"	166	47	4-M6	Fig2	MK1881	2.0
CM20B	155	95	42.5	86.5	184	94	147	106	5	60.5	17.5	30	140	—	150	PT 1"	165	47	4-M6	Fig1	M2091	2.1
CM25B	200	120	44	89.5	230	117	192	—	12	60	21	27	179	—	180	PT 1"	206	47	4-M6	Fig1	M2511	2.4
CM28B	254	170	52	103	285	147	240	182	8	74.5	20.5	20	222.6	278	260	PT 1-1/4"	256	85	4-M6	Fig2	ML2816	4.2
CM33B	300	208	52	101.5	330	—	285	222	8	74.5	20.5	20	262.6	328	259	PT 1-1/4"	308	70	4-M6	Fig2	ML3320	7.2